

Please check the examination details below before entering your candidate information

Candidate surname

Other names

**Pearson Edexcel**  
**International**  
**Advanced Level**

Centre Number

--	--	--	--	--

Candidate Number

--	--	--	--	--

**Friday 5 June 2020**

Afternoon (Time: 1 hour 20 minutes)

Paper Reference **WPH06/01**

**Physics**

**Advanced**

**Unit 6: Experimental Physics**

**You must have:**

Ruler

Total Marks

### Instructions

- Use **black** ink or ball-point pen.
- **Fill in the boxes** at the top of this page with your name, centre number and candidate number.
- Answer **all** questions.
- Answer the questions in the spaces provided  
– *there may be more space than you need.*

### Information

- The total mark for this paper is 40.
- The marks for **each** question are shown in brackets  
– *use this as a guide as to how much time to spend on each question.*
- The list of data, formulae and relationships is printed at the end of this booklet.
- Candidates may use a scientific calculator.

### Advice

- Read each question carefully before you start to answer it.
- Try to answer every question.
- Check your answers if you have time at the end.

Turn over ►

P65748A

©2020 Pearson Education Ltd.

1/1/1/1



  
Pearson

**Answer ALL questions.**

**1** A student made measurements to determine the density of the metal from which a coin was made.

She was given 20 identical coins and a set of vernier calipers.

(a) (i) Describe how she should accurately determine the diameter  $d$  of a coin.

(2)

.....

.....

.....

.....

(ii) The student estimated the thickness of a single coin to be approximately 2 mm. She measured the thickness of 20 coins stacked together to determine the mean thickness of a single coin.

Explain why this would result in a better value for the thickness  $t$  of a single coin.

(3)

.....

.....

.....

.....

.....

.....

DO NOT WRITE IN THIS AREA

DO NOT WRITE IN THIS AREA

DO NOT WRITE IN THIS AREA



(b) The student measured  $d$  as 2.24 cm and  $20t$  as 5.76 cm.

(i) The mass  $m$  of 20 coins was measured as 190.4 g.

Determine the density  $\rho$  of the metal of the coins in  $\text{g cm}^{-3}$ .

(2)

$\rho = \dots\dots\dots \text{g cm}^{-3}$

(ii) State why it is important that the percentage uncertainty in  $d$  is small.

(1)

(iii) The uncertainty in the measurement of  $d$  was  $\pm 0.01$  cm and the uncertainty in the measurement of  $20t$  was  $\pm 0.03$  cm. The uncertainty in the measurement of the mass was negligible.

Deduce whether the coins could be made from cupronickel, which has a density of  $8.86 \text{ g cm}^{-3}$ . You should include calculations in your answer.

(4)

(Total for Question 1 = 12 marks)



2 The diameter of a single hair can be determined by shining a laser beam onto it.

(a) State one safety precaution that should be observed when using a laser.

(1)

(b) When the laser is switched on, light diffracts from each side of the hair and acts as two coherent sources of light, separated by the width of the hair. This produces an interference pattern on a screen.

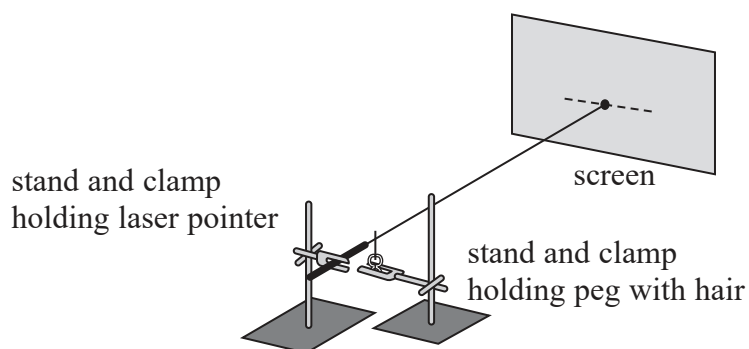

Explain how positions of minimum intensity are formed on the screen.

(2)



DO NOT WRITE IN THIS AREA

DO NOT WRITE IN THIS AREA

DO NOT WRITE IN THIS AREA

(c) The diameter  $d$  of the hair can be determined from the formula

$$d = \frac{\lambda D}{s}$$

where  $\lambda$  is the wavelength of the laser light,  $D$  is the distance from the hair to the screen and  $s$  is the distance between consecutive minima.

Explain the effect of doubling  $D$  on the percentage uncertainty in  $d$ .

(3)

.....

.....

.....

.....

.....

.....

.....

.....

.....

.....

(Total for Question 2 = 6 marks)



- 3 The luminosity of a filament bulb depends on the power input  $P$  to the filament bulb. The radiation flux  $F$  received by a light sensor positioned a fixed distance away from the bulb can be taken as a measure of the luminosity of the filament bulb.

It is suggested that the relationship between  $P$  and  $F$  is given by

$$P = kF^4$$

where  $k$  is a constant.

- (a) Describe the measurements that should be made to test the relationship.

(2)

.....

.....

.....

.....

.....

.....

- (b) Draw a circuit diagram to show how the filament bulb should be connected.

(2)



(c) Explain how the measurements will be used to test the validity of the relationship.

(4)

DO NOT WRITE IN THIS AREA

DO NOT WRITE IN THIS AREA

DO NOT WRITE IN THIS AREA

(Total for Question 3 = 8 marks)



- 4 A student investigated how the resistance  $R$  of a thermistor varied with its temperature  $\theta$ .

The thermistor was placed in a beaker of hot water. The beaker was allowed to cool. The student measured  $R$  using an ohmmeter at different values of  $\theta$  measured with a thermometer.

- (a) State two techniques he should use to ensure that the measurement of  $\theta$  is as accurate as possible.

(2)

.....

.....

.....

.....

- (b) The student obtained the following results.

$\theta / ^\circ\text{C}$	$R / \text{k}\Omega$	
80	0.625	
65	1.11	
50	1.95	
35	3.46	
20	6.11	
5	10.80	
0	13.1	

The relationship between  $R$  and  $\theta$  is given by

$$R = R_0 e^{-\alpha\theta}$$

where  $R_0$  is the resistance of the thermistor at  $0^\circ\text{C}$  and  $\alpha$  is a constant.

- (i) Plot a graph of  $\ln R$  against  $\theta$  on the grid opposite. Use the additional column in the table to record your processed data.

(5)





DO NOT WRITE IN THIS AREA

DO NOT WRITE IN THIS AREA

DO NOT WRITE IN THIS AREA

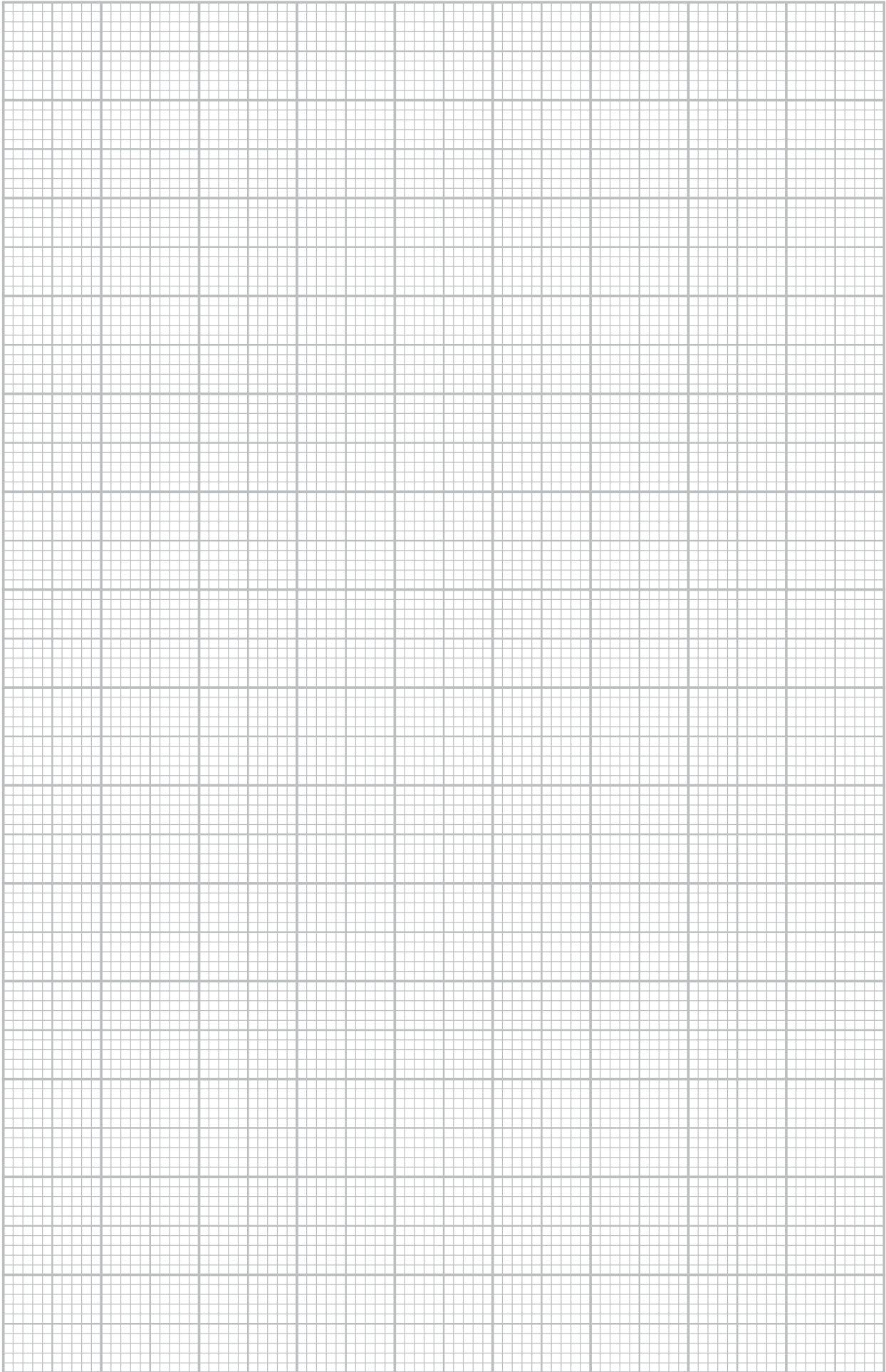

(ii) Use your graph to determine a value for  $\alpha$ .

(4)

$\alpha =$  .....

(iii) The student uses the thermistor with a resistor in a circuit as shown.

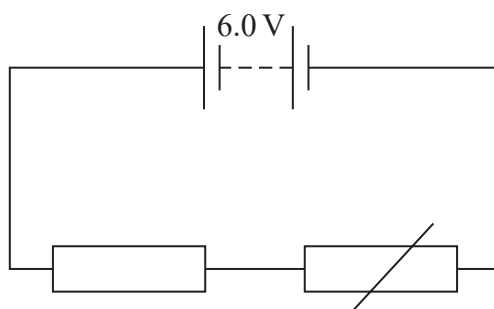

The thermistor acts as a temperature sensor. When the temperature reaches  $0^{\circ}\text{C}$ , the potential difference across the thermistor becomes  $5.0\text{ V}$ , which switches on a heater.

Calculate a value for the resistance of the resistor at  $0^{\circ}\text{C}$ .

(3)

Resistance of resistor at  $0^{\circ}\text{C} =$  .....

**(Total for Question 4 = 14 marks)**

**TOTAL FOR PAPER = 40 MARKS**

DO NOT WRITE IN THIS AREA

DO NOT WRITE IN THIS AREA

DO NOT WRITE IN THIS AREA



DO NOT WRITE IN THIS AREA

DO NOT WRITE IN THIS AREA

DO NOT WRITE IN THIS AREA

**BLANK PAGE**



### List of data, formulae and relationships

Acceleration of free fall	$g = 9.81 \text{ m s}^{-2}$	(close to Earth's surface)
Boltzmann constant	$k = 1.38 \times 10^{-23} \text{ J K}^{-1}$	
Coulomb's law constant	$k = 1/4\pi\epsilon_0$ $= 8.99 \times 10^9 \text{ N m}^2 \text{ C}^{-2}$	
Electron charge	$e = -1.60 \times 10^{-19} \text{ C}$	
Electron mass	$m_e = 9.11 \times 10^{-31} \text{ kg}$	
Electronvolt	$1 \text{ eV} = 1.60 \times 10^{-19} \text{ J}$	
Gravitational constant	$G = 6.67 \times 10^{-11} \text{ N m}^2 \text{ kg}^{-2}$	
Gravitational field strength	$g = 9.81 \text{ N kg}^{-1}$	(close to Earth's surface)
Permittivity of free space	$\epsilon_0 = 8.85 \times 10^{-12} \text{ F m}^{-1}$	
Planck constant	$h = 6.63 \times 10^{-34} \text{ J s}$	
Proton mass	$m_p = 1.67 \times 10^{-27} \text{ kg}$	
Speed of light in a vacuum	$c = 3.00 \times 10^8 \text{ m s}^{-1}$	
Stefan-Boltzmann constant	$\sigma = 5.67 \times 10^{-8} \text{ W m}^{-2} \text{ K}^{-4}$	
Unified atomic mass unit	$u = 1.66 \times 10^{-27} \text{ kg}$	

### Unit 1

#### Mechanics

Kinematic equations of motion	$v = u + at$ $s = ut + \frac{1}{2}at^2$ $v^2 = u^2 + 2as$
Forces	$\Sigma F = ma$ $g = F/m$ $W = mg$
Work and energy	$\Delta W = F\Delta s$ $E_k = \frac{1}{2}mv^2$ $\Delta E_{\text{grav}} = mg\Delta h$

#### Materials

Stokes' law	$F = 6\pi\eta rv$
Hooke's law	$F = k\Delta x$
Density	$\rho = m/V$
Pressure	$p = F/A$
Young modulus	$E = \sigma/\epsilon$ where Stress $\sigma = F/A$ Strain $\epsilon = \Delta x/x$
Elastic strain energy	$E_{\text{el}} = \frac{1}{2}F\Delta x$



**Unit 2***Waves*

Wave speed

$$v = f\lambda$$

Refractive index

$${}_1\mu_2 = \sin i / \sin r = v_1 / v_2$$

*Electricity*

Potential difference

$$V = W/Q$$

Resistance

$$R = V/I$$

Electrical power, energy and efficiency

$$P = VI$$

$$P = I^2R$$

$$P = V^2/R$$

$$W = VI t$$

$$\% \text{ efficiency} = \frac{\text{useful energy output}}{\text{total energy input}} \times 100$$

$$\% \text{ efficiency} = \frac{\text{useful power output}}{\text{total power input}} \times 100$$

Resistivity

$$R = \rho l/A$$

Current

$$I = \Delta Q / \Delta t$$

$$I = nqvA$$

Resistors in series

$$R = R_1 + R_2 + R_3$$

Resistors in parallel

$$\frac{1}{R} = \frac{1}{R_1} + \frac{1}{R_2} + \frac{1}{R_3}$$

*Quantum physics*

Photon model

$$E = hf$$

Einstein's photoelectric equation

$$hf = \phi + \frac{1}{2}mv_{\text{max}}^2$$



**Unit 4***Mechanics*

Momentum	$p = mv$
Kinetic energy of a non-relativistic particle	$E_k = p^2/2m$
Motion in a circle	$v = \omega r$ $T = 2\pi/\omega$ $F = ma = mv^2/r$ $a = v^2/r$ $a = r\omega^2$

*Fields*

Coulomb's law	$F = kQ_1Q_2/r^2$ where $k = 1/4\pi\epsilon_0$
Electric field	$E = F/Q$ $E = kQ/r^2$ $E = V/d$
Capacitance	$C = Q/V$
Energy stored in capacitor	$W = \frac{1}{2}QV$
Capacitor discharge	$Q = Q_0 e^{-t/RC}$
In a magnetic field	$F = BIl \sin \theta$ $F = Bqv \sin \theta$ $r = p/BQ$
Faraday's and Lenz's laws	$\epsilon = -d(N\phi)/dt$

*Particle physics*

Mass-energy	$\Delta E = c^2 \Delta m$
de Broglie wavelength	$\lambda = h/p$



## Unit 5

### Energy and matter

Heating  $\Delta E = mc\Delta\theta$

Molecular kinetic theory  $\frac{1}{2}m\langle c^2 \rangle = \frac{3}{2}kT$

Ideal gas equation  $pV = NkT$

### Nuclear Physics

Radioactive decay  $dN/dt = -\lambda N$

$$\lambda = \ln 2/t_{1/2}$$

$$N = N_0 e^{-\lambda t}$$

### Mechanics

Simple harmonic motion

$$a = -\omega^2 x$$
$$a = -A\omega^2 \cos \omega t$$
$$v = -A\omega \sin \omega t$$
$$x = A \cos \omega t$$
$$T = 1/f = 2\pi/\omega$$

Gravitational force  $F = Gm_1 m_2 / r^2$

### Observing the universe

Radiant energy flux  $F = L/4\pi d^2$

Stefan-Boltzmann law

$$L = \sigma T^4 A$$
$$L = 4\pi r^2 \sigma T^4$$

Wien's law  $\lambda_{\max} T = 2.898 \times 10^{-3} \text{ m K}$

Redshift of electromagnetic radiation  $z = \Delta\lambda/\lambda \approx \Delta f/f \approx v/c$

Cosmological expansion  $v = H_0 d$

DO NOT WRITE IN THIS AREA



DO NOT WRITE IN THIS AREA

DO NOT WRITE IN THIS AREA

DO NOT WRITE IN THIS AREA

**BLANK PAGE**

